

EVC 7000

Fireman Intercom System

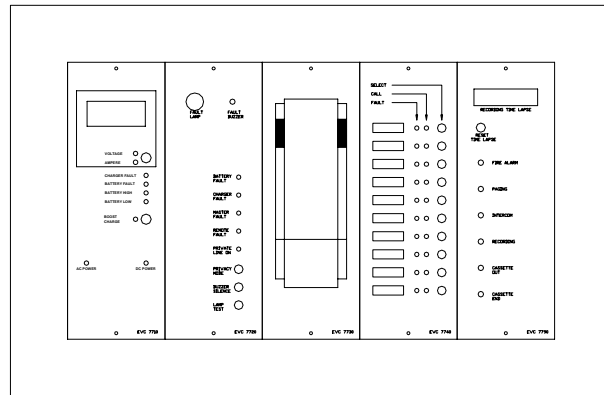

USER MANUAL

Content

1	System Overview	1
2	System Configuration	2
3	The Control Panels	3
3.1	The Master Control Panel	3
3.2	Battery Charger Module.....	4
3.3	Common Trouble Indicator Module	4
3.4	Master Handset Module	4
3.5	Handset Zone Selector Module.....	4
3.6	Cassette Interface Module (Optional)	4
4	Panel Wiring	5
5	Operating Instructions	7
5.1	Remote station calling Master station	7
5.2	Master station calling Remote station	7
5.3	Master station calling multiple Remote stations	7
5.4	Privacy Mode	8
6	Installing the system	9
6.1	Mounting the master console panel.....	9
6.2	Mounting the remote handset (Surface type).....	10
6.3	Mounting the remote handset (Flush type)	11
6.4	Terminating of remote handset to Master Console Panel	12
7	Troubleshooting the system	13
7.1	FAQ.....	13
7.2	Fault finding flow chart.....	14
8	Technical Specifications	15
8.1	Battery Charger Module (EVC 7710/X)	15
8.2	Common Trouble Indicator Module (EVC 7720).....	15
8.3	Master Handset Module (EVC 7730)	16
8.4	Handset Zone Selector Module (EVC 7740)	16
8.5	Remote Handset	17
	Appendix A	18
	Setting the number of zone.....	18
	Note	20

1 System Overview

The EVC 7000 Series supervised Firemen Intercom System provides two ways communication for use during emergencies.

The system provides control and transmission of signals and line monitoring that complies with SISIR CP 25 and in accordance with the following: -

1. Two ways selective communication between Master Control Panel and a specified number of Remote Handsets located at designated points on each floor of the building.
2. Selective handset CALL enunciators at the Master Control Panel.
3. Supervision of complete system, including wiring to all Remote Handsets, with audible and visual warning of any system malfunction and their locations.
4. Provision of an automatic standby power supply for backup purposes.

The system's equipment can be broadly categorised as: -

1. Equipment located inside the Fire Command Centre of the building.
2. Remote equipment at various points throughout the building.

2 System Configuration

The following figure shows a typical Configuration of EVC 7000 Series Firemen Intercom System. A length of 2-core 1.5mm² FR cable is laid from the Master Control Panel to each individual Remote Handset. This system has the advantage of direct communication between Remote station and Master station. It can act as a stand-alone set and can be isolated from the other Remote Handsets if the latter is found to be faulty. Thus system can be easily maintained and the defective Remote Handsets can be serviced without affecting the entire communication system.

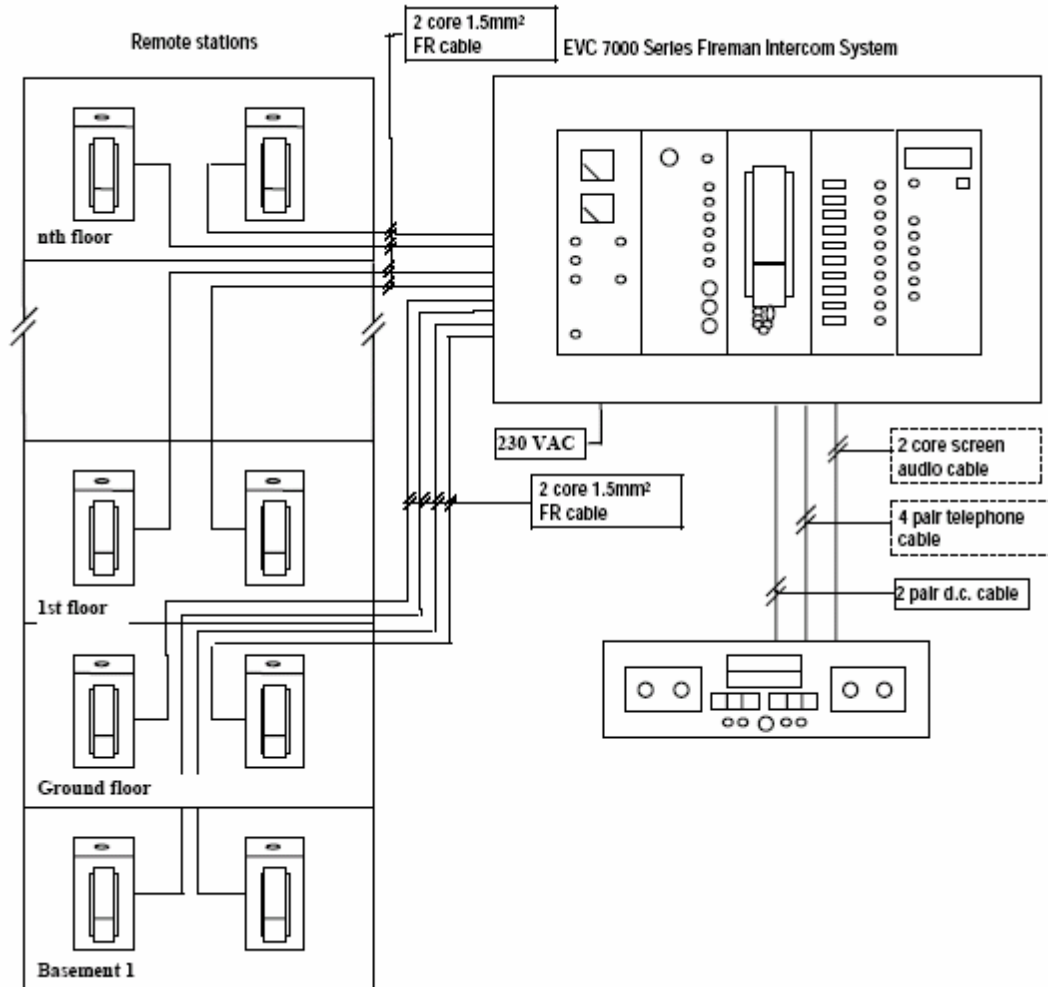

Figure 1 Firemen Intercom System Configuration

3 The Control Panels

The following figure shows a typical 10 zone Firemen Intercom System configuration.

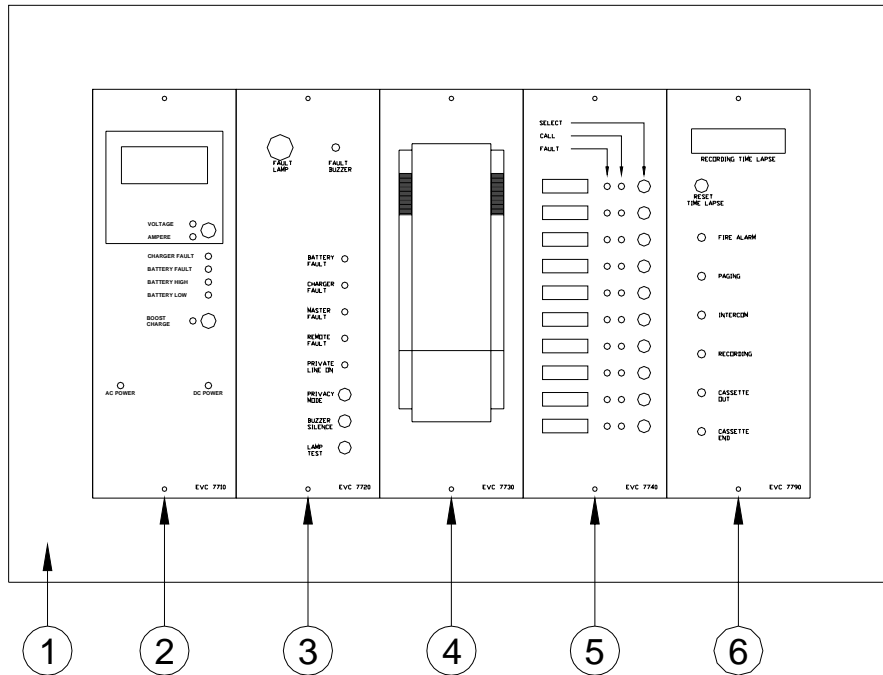

Figure 2 A 10 zone Firemen Intercom System

1. Master Control
2. Battery Charger Module
3. Common Trouble Indicator Module
4. Master Handset Module
5. Handset Zone Selector Module
6. Cassette Interface Module (Optional)

Description	Model Number	Remarks
Master Control Panel	EVC 7700 / x	Where x is the nos. of module
Battery Charger Module c/w batteries	EVC 7710 / x	Where x is the nos. of ampere hours
Common Trouble Indicator Module	EVC 7720	One module per system
Master Handset Module	EVC 7730	One module per system
Handset Zone Selector Module	EVC 7740	10 zones per module
Line Supervisory Card	EVC 7741	One card per zone
Remote Handset	EVC 7750	One remote handset per zone
Cassette Interface Module c/w Recorder	EVC 7790	As required

3.1 The Master Control Panel

All modules are installed in the master control panel. Depending on the number of zone and optional module the master control panel may increase in size.

3.2 Battery Charger Module

The Battery Charger Module comprises of the rectification circuit and charging circuit. It is a highly efficiency switching power supply with charger which provide DC power supply to the system and at the same time it will tickle charge the batteries. During AC power failure, it will provide backup power supply to the system.

It has the following features: -

1. Digital Volt/Ampere meter
2. AC/DC fuse protection.
3. Float and Boost mode.
4. Automatic boost charge cut off.
5. AC main switch and fuse are internal to prevent tampering.

3.3 Common Trouble Indicator Module

The common Trouble Indicator Module comprises of LED indicators for fault monitoring on Battery, Charger, Master, Remote, and Privacy.... etc. It has 3 other push buttons for testing of system, silencing of buzzer and toggling of private on-line / off-line. It also has a general fault lamp to indicate any fault present.

The electronic circuitry consists of the following: -

1. Call generator
2. Busy tone generator
3. Ready tone generator
4. Supervisory circuit
5. Audio circuit
6. Audio extension

3.4 Master Handset Module

The Master Handset Module comprises of the Master Handset, which is used to communicate with the Remote Handsets. It also consists of a 15V Regulator and the CPU circuit.

3.5 Handset Zone Selector Module

Each handset zone selector module can support up to 10 number of remote handset (EVC 7750). Each zone requires a Line Supervisory Card (EVC 7741).

3.6 Cassette Interface Module (Optional)

The Cassette Interface Module interface to the cassette recorder In the event of emergency the tape recorder records the voice traffic of the Firemen Intercom System.

4 Panel Wiring

The following figure shows a typical wiring diagram in the master control panel. Wiring layout may defer depend on system configuration.

- ⚠ CAUTION:** Only a certified service technician should perform repairs or replacement of parts on the system. Damage due to unauthorized personnel is not cover under warranty.
- ⚠ CAUTION:** To prevent static damage to components, discharge static electricity from your body before you touch any of the electronic components.
- ⚠ CAUTION:** Handle components, PC boards and cards with care. Do not touch the components or contacts on the board and card. Hold them by its edges or by its metal mounting bracket. Hold any IC by its edges instead of its pins.

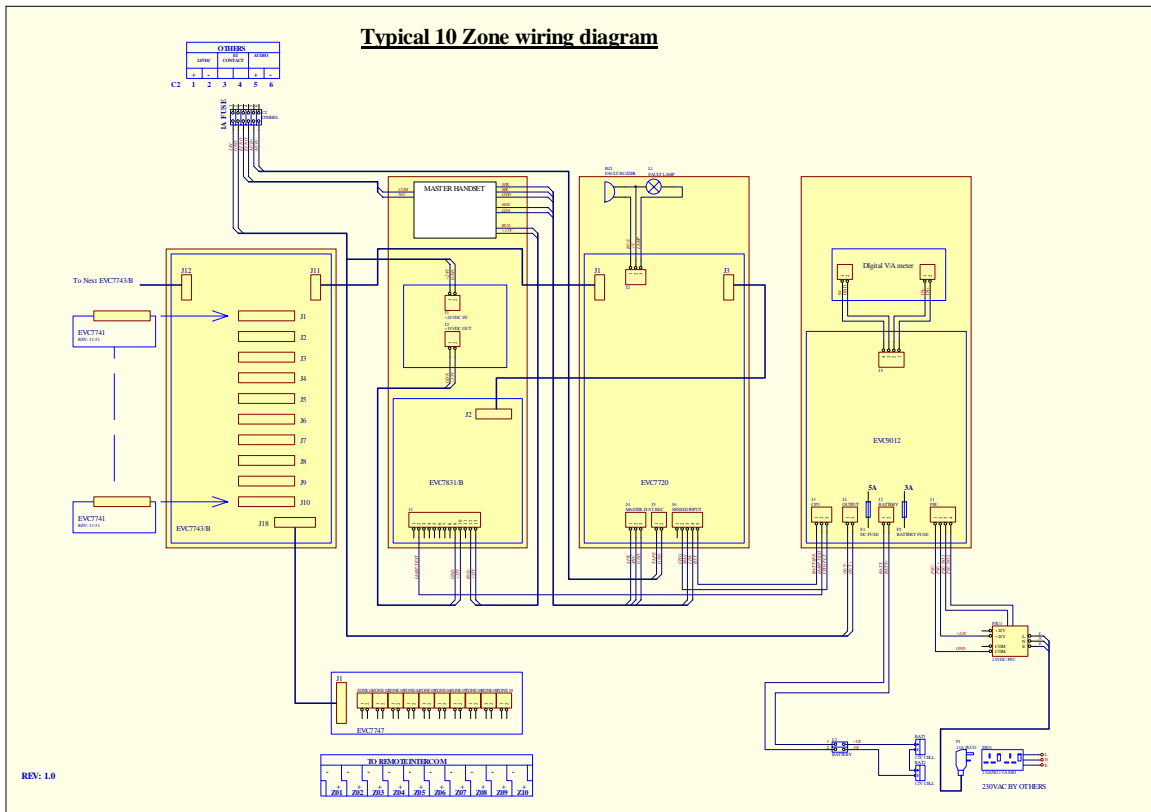

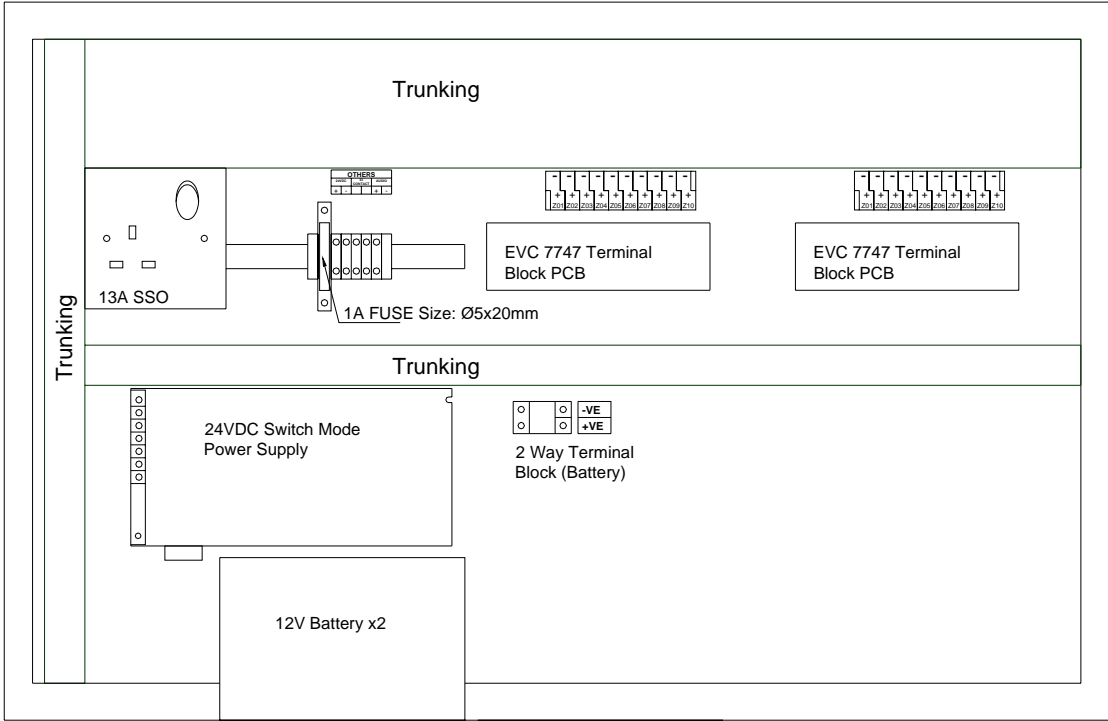

Figure 4 Typical back panel layout

5 Operating Instructions

The Fireman Intercom System provides fire fighters with two-way communication between remote points within the building and the Master Control Panel. This chapter explains the various modes of calling that can be established using the EVC 7000 Series.

5.1 Remote station calling Master station

1. Lift up any handset at the remote station
 - An audible call signal sounded at the Master control Panel
 - The respective **CALL** indicator flash
2. Lift up the master handset
 - The audible call signal is silence
 - The **PRIVACY LINE-ON** turns on
 - The respective **CALL** indicator change from flashing to steady
 - Communication between the Remote Handset and Master Handset is established
3. Subsequent Lifting of Remote Handset will
 - Flashes the respective **CALL** indicator (on-hold)
 - Depress the respective **SELECT** switch
 - The respective **CALL** indicator change from flashing to steady
 - Communication between the Remote Handset(s) and Master Handset is established

5.2 Master station calling Remote station

1. Lift up the Master Handset
 - The **PRIVACY LINE-ON** indicator turns on
 - Depress the desire **SELECT** switch.
 - The respective **CALL** indicator flash
 - The Remote Handset will sound off
2. Lift up the Remote Handset.
 - The respective **CALL** indicator change from flashing to steady
 - Communication between the Remote Handset and Master Handset is established

5.3 Master station calling multiple Remote stations

Communication may be established between the Master Control Panel and one or more Remote Handsets, thus providing a 'Conference' Communication Network.

1. Lift up the Master Handset and depress the **SELECT** switches (for one or more Remote Handsets).
 - The **CALL** indicator flash
 - The various Remote Handsets will sound off

2. The Master Control Panel can cancel the call to any particular Remote Handset by depressing the **SELECT** switch again.
 - This double pressing action cancels the selecting mode to the Remote Handset
 - The flashing enunciator light should go off to indicate that the calling has been cancelled
 - The Remote Handset will go into silence again
3. When the respective Remote Handsets are lifted.
 - The respective **CALL** indicator change from flashing to steady
 - Communication between the Remote Handset and Master Handset is established



5.4 Privacy Mode

The **Privacy Mode** feature is enabled by default. Disabling the Privacy Mode will put the system in conferencing mode. In conferencing mode any in-coming call from remote handset will be put through.

1. Lift up the Master Handset
 - The **PRIVACY LINE-ON** indicator turns on (enabled by default)
 - Depress the desire **PRIVACY MODE** switch.
 - The **PRIVACY LINE-ON** indicator turns off
 - Depress the desire **SELECT** switch
 - The respective **CALL** indicator flash
 - The Remote Handset will sound off
2. Lift up the Remote Handset.
 - The respective **CALL** indicator change from flashing to steady
 - Communication between the Remote Handset and Master Handset is established
3. Subsequent Lifting of Remote Handset will
 - Turns on the respective **CALL** indicator (steady)
 - Communication between the Remote Handsets and Master Handset is established

6 Installing the system

This section provides a typical method on installing the Console and remote handset.

-  **CAUTION:** Only a certified service technician should perform repairs or replacement of parts on the system. Damage due to unauthorized personnel is not cover under warranty.
-  **CAUTION:** To prevent static damage to components, discharge static electricity from your body before you touch any of the electronic components.
-  **CAUTION:** Handle components, PC boards and cards with care. Do not touch the components or contacts on the board and card. Hold them by its edges or by its metal mounting bracket. Hold any IC by its edges instead of its pins.

6.1 Mounting the master console panel

The console can be mounted on to the wall by using metal wall plugs as shown in *Figure 5*. Sufficient clearance should be given to cable entries hole.

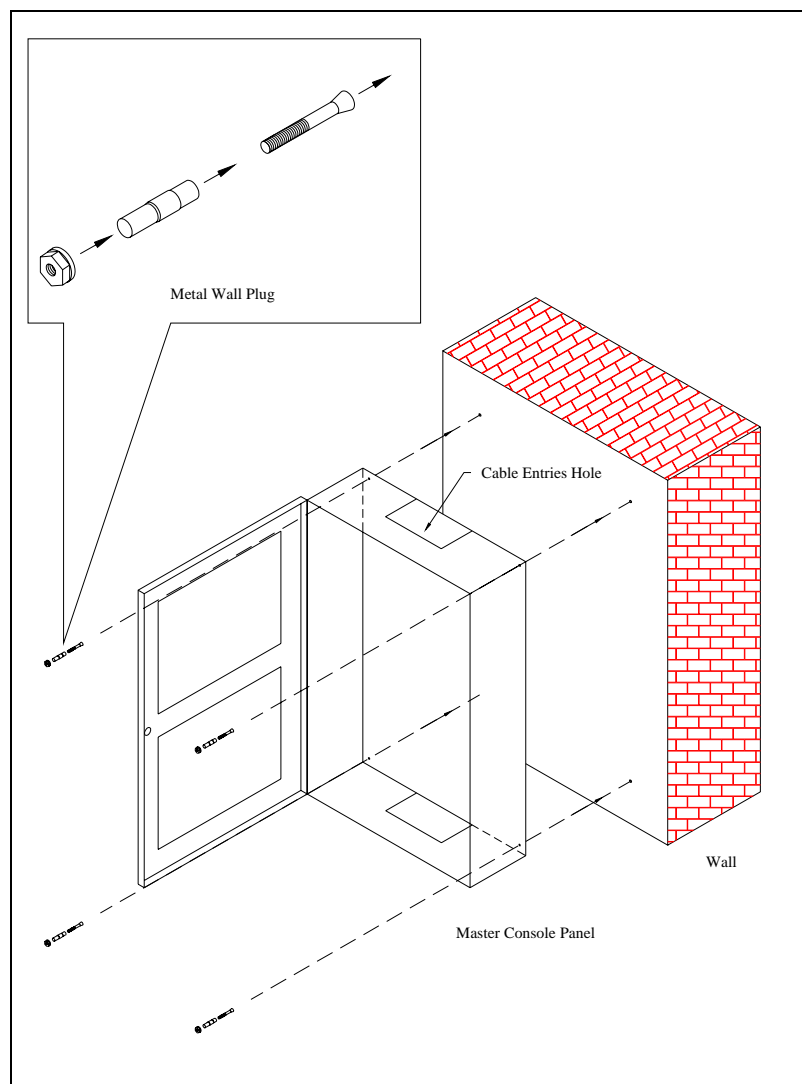

Figure 5 Mounting the console

6.2 Mounting the remote handset (Surface type)

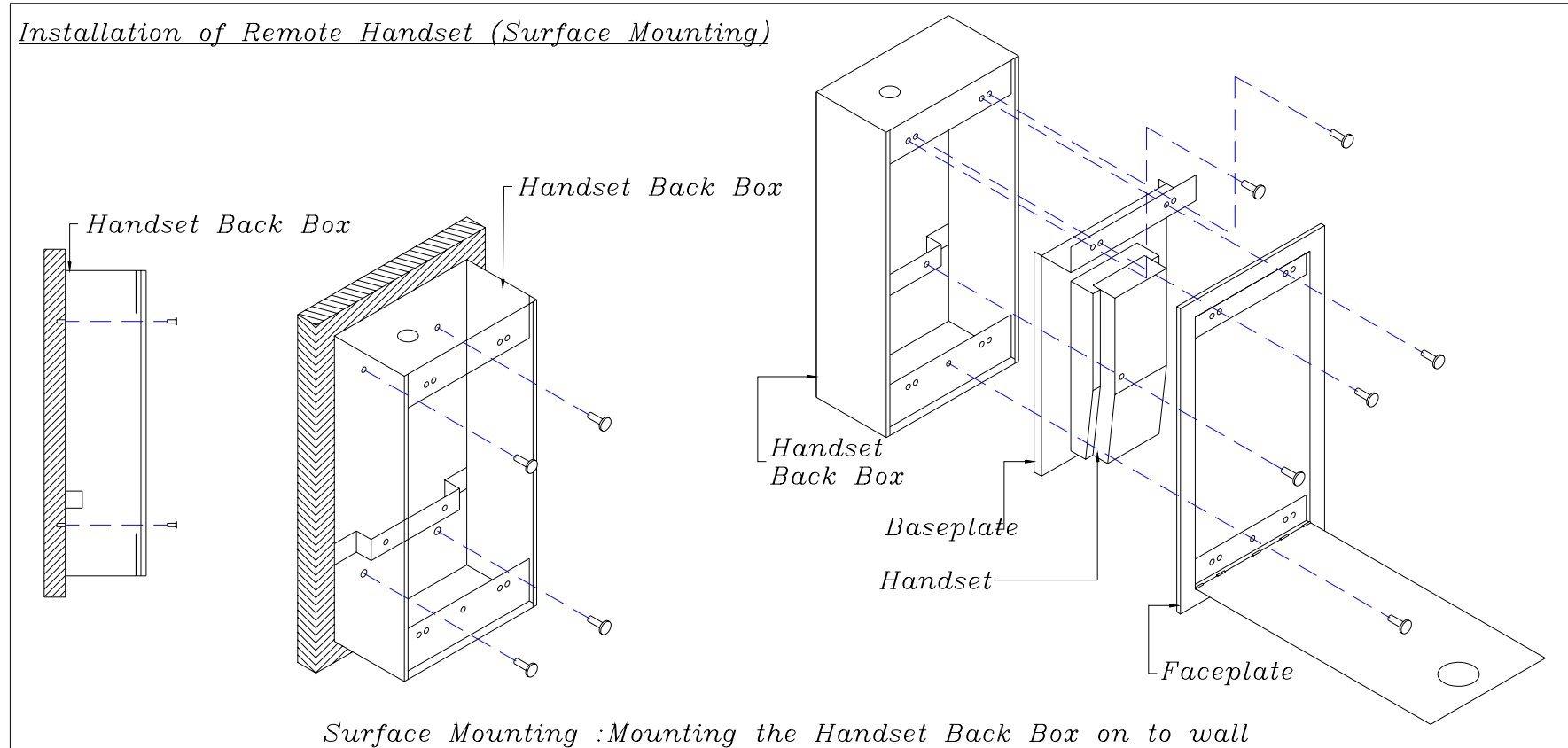

Figure 6 Mounting the remote handset enclosure (Surface type)

6.3 Mounting the remote handset (Flush type)

Installation of Remote Handset (Flush Mounting)

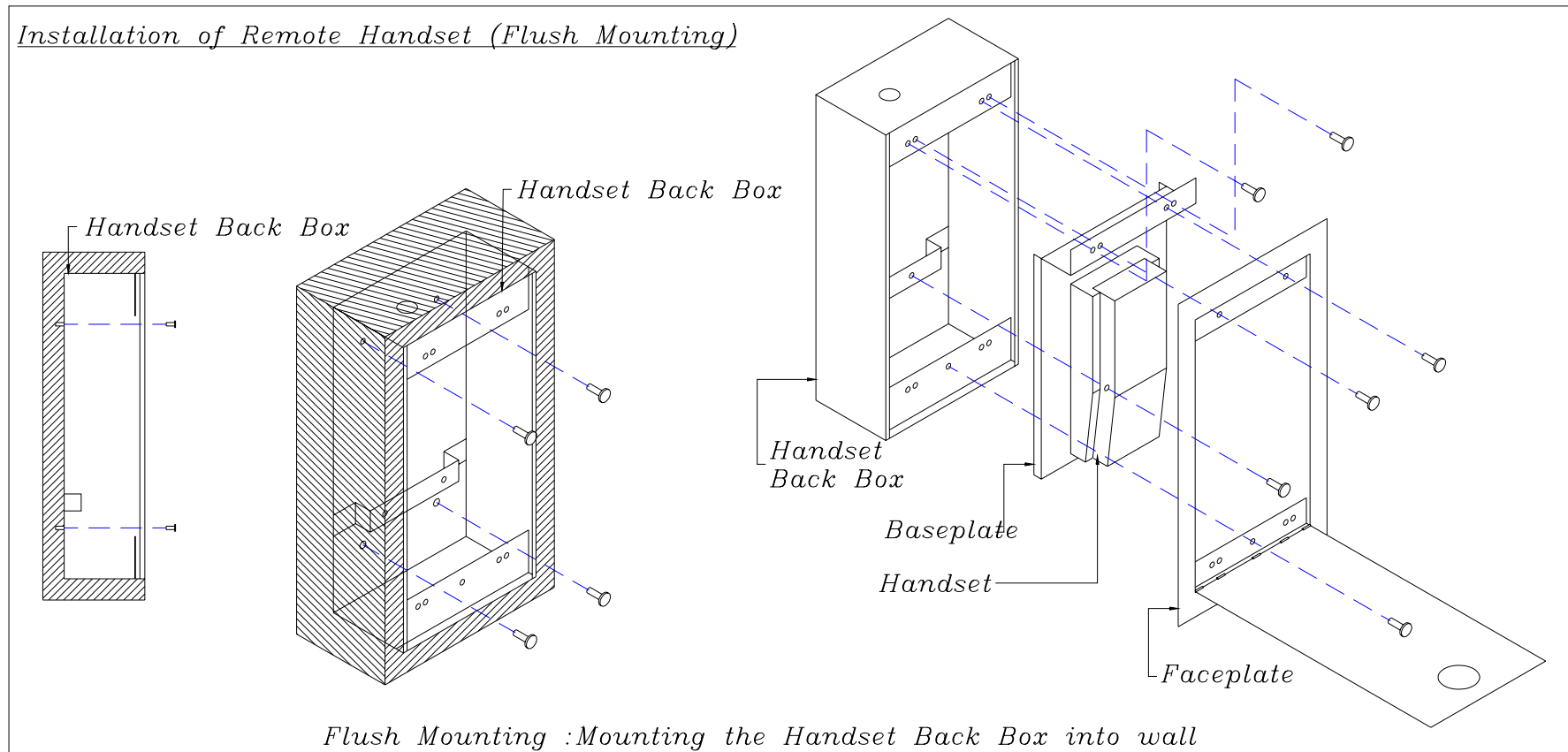





Figure 7 Mounting the remote handset enclosure (Flush type)

6.4 Terminating of remote handset to Master Console Panel

The Master Console Panel are pre terminate with a 1 kilo-ohms resistor in each zone. The respective zone resistor has to be **REMOVE** when the remote handset is connected across the respective zone.

-  **CAUTION:** Only a certified service technician should perform repairs or replacement of parts on the system. Damage due to unauthorized personnel is not cover under warranty.
-  **CAUTION:** To prevent static damage to components, discharge static electricity from your body before you touch any of the electronic components.
-  **CAUTION:** Handle components, PC boards and cards with care. Do not touch the components or contacts on the board and card. Hold them by its edges or by its metal mounting bracket. Hold any IC by its edges instead of its pins.

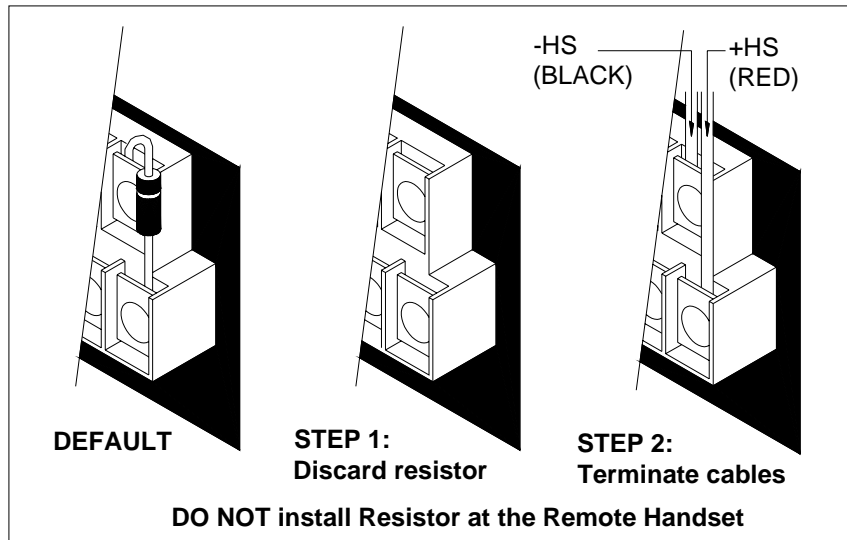





Figure 8 Terminating the remote handset

7 Troubleshooting the system

This following FAQ provides some of the most common fault that the installer/user may encounter during installation and operation.

-  **CAUTION:** Only a certified service technician should perform repairs or replacement of parts on the system. Damage due to unauthorized personnel is not cover under warranty.
-  **CAUTION:** To prevent static damage to components, discharge static electricity from your body before you touch any of the electronic components.
-  **CAUTION:** Handle components, PC boards and cards with care. Do not touch the components or contacts on the board and card. Hold them by its edges or by its metal mounting bracket. Hold any IC by its edges instead of its pins.

7.1 FAQ

The CALL indicator of the respective zone(s) flash and call buzzer sounds
<ul style="list-style-type: none">• Is the remote station calling the master station?• Is the remote station handset not properly hooked onto the cradle?• Is the preinstalled 1 kΩ resistor removed?• Is the 1 kΩ resistor installed at the remote handset?
The CALL indicators(s) flash, FAULT LAMP/BATTERY FAULT indicator lights up and FAULT Buzzer sounds
<ul style="list-style-type: none">• Is the power supply voltage at 24V?
The FAULT LAMP/BATTERY FAULT indicator lights up and FAULT Buzzer sounds
<ul style="list-style-type: none">• Is the power supply voltage at 24V?
The FAULT and the CALL indicator(s) of the respective zone lights
<ul style="list-style-type: none">• Is the number of zone for the system set correctly?

7.2 Fault finding flow chart

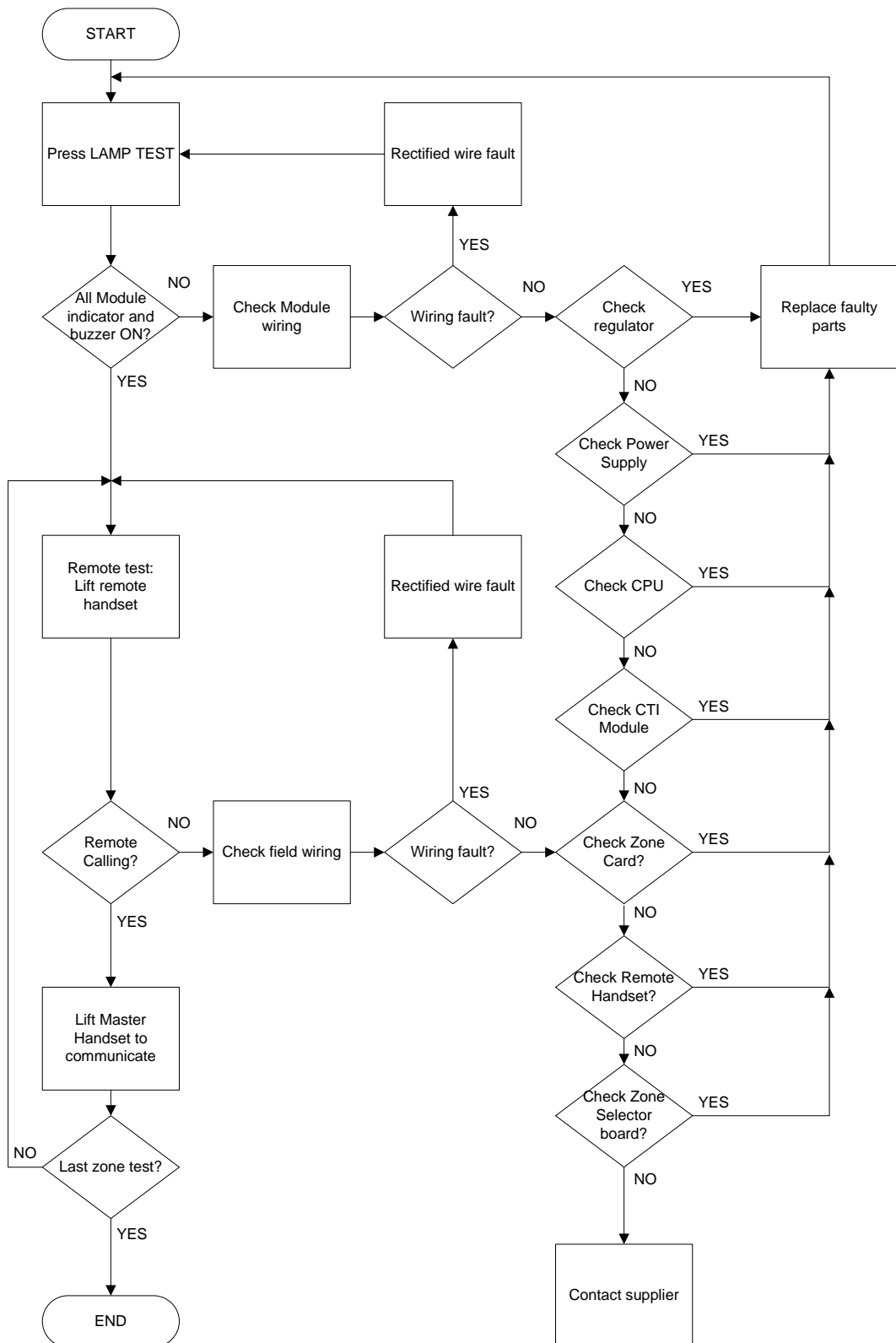

Figure 9 Fault finding flow chart

8 Technical Specifications

8.1 Battery Charger Module (EVC 7710/X)

Mechanical Specifications

Dimension	110(W) x 316(H) x 110(D) mm
Weight	1750g
Material	Aluminum
Finish	Brush Anodized, natural color

Electrical Specifications

Input Voltage	230V AC
Output Voltage	28.8V +/-0.5 VDC, 4A
DC Fuse	5A
Battery Fuse	3A
24V Output fuse	1A

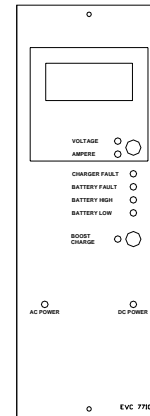

8.2 Common Trouble Indicator Module (EVC 7720)

Mechanical Specifications

Dimension	110(W) x 316(H) x 52(D) mm
Weight	350g
Material	Aluminum
Finish	Brush Anodized, natural color

Electrical Specifications

Input Voltage	15V DC
Current	Approximate 25mA (Normal) Approximate 200mA (Lamp Test)

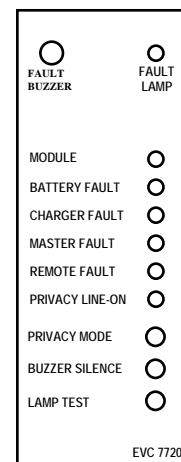

8.3 Master Handset Module (EVC 7730)

Mechanical Specifications

Dimension	110(W) x 316(H) x 100(D) mm
Weight	630g
Material	Aluminum
Finish	Brush Anodized, natural color
Handset	Enclosed in Red Hi-impact ABS plastic

Electrical Specifications

Input Voltage (Buzzer)	24V DC
Current	Approximate 20mA (Normal)
Ring Frequency	2kHz
Microphone	Carbon
Output impedance	300-1000 ohm
Frequency respond	200-3000 Hz
Ear piece	Electro mechanical
Impedance	300 ohm
Frequency respond	200-3450 Hz

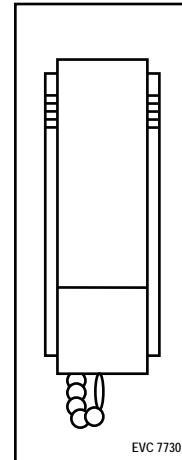

8.4 Handset Zone Selector Module (EVC 7740)

Mechanical Specifications

Dimension	110(W) x 316(H) x 100(D) mm
Weight	510g

Electrical Specifications

Input Voltage (Buzzer)	15V DC
Current	Approximate 25mA (Normal) Approximate 200mA (Lamp Test)

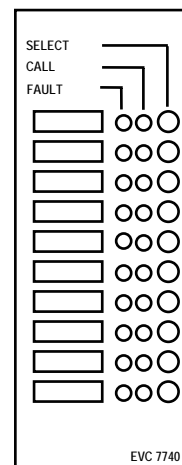

8.5 Remote Handset

Mechanical Specifications

Dimension	180(W) x 380(H) x 88(D) mm
Face Plate (Surface)	196mm(W) x 360mm(H)
Face Plate (Flush)	203mm(W) x 380mm(H)
Weight (With Handset)	3950g
Material	16 gauge sheet steel
Finish	Red color powder coated paint

Electrical Specifications

See EVC 7730

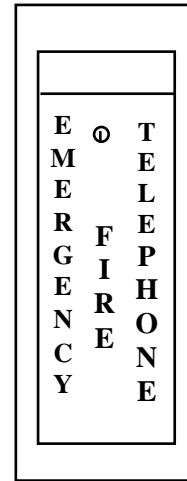



Appendix A

Setting the number of zone

EVC 7831 CPU Board

The EVC 7831 CPU board is the heart of the system. It controls the number of zone that can be handled and other functionality of the system.

-  **CAUTION:** Only a certified service technician should perform repairs or replacement of parts on the system. Damage due to unauthorized personnel is not cover under warranty.
-  **CAUTION:** To prevent static damage to components, discharge static electricity from your body before you touch any of the electronic components.
-  **CAUTION:** Handle components, PC boards and cards with care. Do not touch the components or contacts on the board and card. Hold them by its edges or by its metal mounting bracket. Hold any IC by its edges instead of its pins.

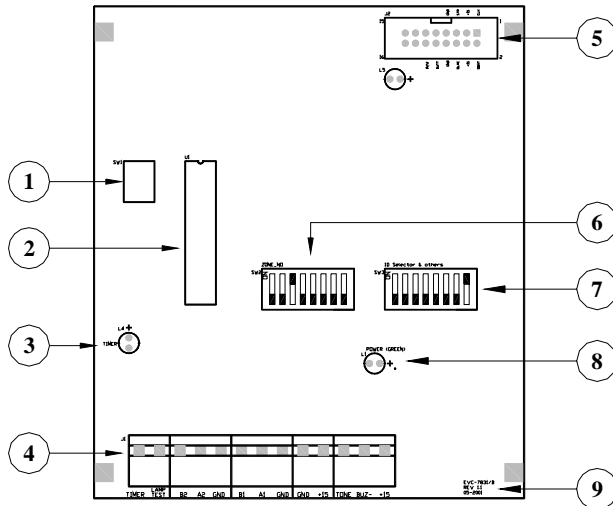

1. SW1 Soft RESET switch
2. U1 Central Processor Unit (CPU)
3. L4 Tone indicator
4. J1 8 way connector
5. J2 CTI & Zone Selector board (EVC 7900) box header
6. SW2 ZONE_NO zone configuration switch
7. ID selector and other function switch
8. L1 POWER ON LED (GREEN)
9. Board Part Number

SW1 Soft RESET switch

When press, the system will be reset. All indicators will be ON, Fault buzzer will be sound and remote indicator will be ON.

SW2 ZONE NO Zone configuration switch

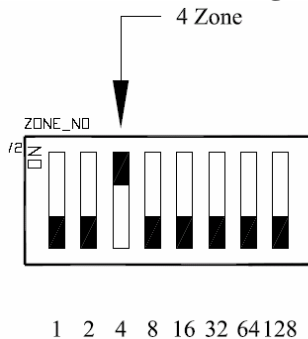

The number of zone that can be handled by the system can be configured by setting SW2. E.g. for a 11 zone system SW2:1, SW2:2 and SW2:4 must be ON. The rest of the switches (SW2:3 and SW2:5-8 OFF).

SW3 ID Selector and other function switch

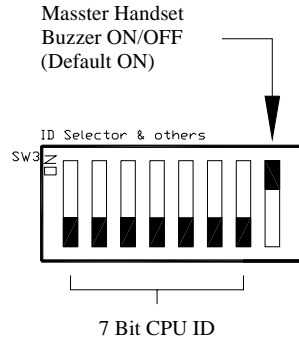

The 7-bit (SW3:1-SW3:7) CPU ID is use to operate the system in expanded mode. If a single CPU is install in the system SW3:1-SW7 must be OFF (Default). SW3:8 is use to set the Master handset internal buzzer ON or OFF for testing purpose.

U1 Central Processor Unit (CPU)

The brain of the system is resided in the CPU.

