

EVC 7790

Cassette Interface System

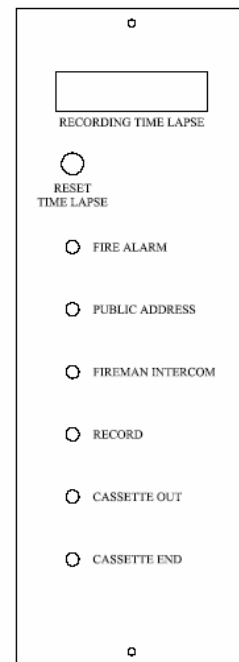

USER MANUAL

Content

Chapter 1 Introduction	1
Chapter 2 EVC 7790 Cassette Interface System.....	2
2.1 Cassette Interface Module.....	2
2.1.1 Front View	2
2.1.2 Terminal blocks	4
2.2 Modified Cassette Recorder.....	5
Chapter 3 System Operation	6
3.1 System Setup Procedure	6
3.1.1 Connection and Power Supply.....	6
3.1.2 Modified Cassette Recorder.....	8
3.1.3 Cassette Interface Display Panel.....	8
3.2 System Operation.....	9
3.2.1 Bringing the System into Standby Mode (Reset Button).....	9
3.2.2 Recording Process.....	9
3.2.3 Cassette Out & Cassette End	9
Chapter 4 Frequently Asked Questions	10
Notes	11
Cassette Recorder User Manual.....	12

Chapter 1 Introduction

The EVC 7790 Cassette Interface System (CIS) is designed to interface to a cassette recorder. The interface unit provides auto activation of recorder upon detecting of triggering source (Fire Alarm). The system also provides various indications which conform to the requirements stated in Singapore Standard CP25:1999, Code of Practice for Emergency Voice Communication System in Building.

The system has the following features;

- Recording of emergency voice communication upon fire alarm activation
- Status indicator for Public Addressing System and Fireman Intercom System
- Recording timer up to 9 hr 59 min
- Automatic recovery on power failure
- Status indicator of the cassette recorder such as Cassette out and cassette end

Chapter 2 EVC 7790 Cassette Interface System

The EVC 7790 Cassette Interface System consists of two main components, a cassette interface module and a modified cassette recorder.

2.1 Cassette Interface Module

The Cassette Interface module detects signals from Fire Alarms and triggers the recorder automatically. The interface unit operates at +24VDC and house in the Fireman Intercom System (Refer to Fireman Intercom System user manual).

2.1.1 Front View

The front panel provides visual indication for user. The following diagram shows detailed information of each visual indicator.

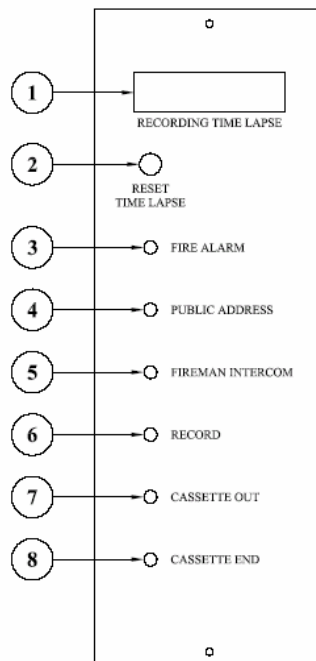

Figure 2-1 The cassette interface module front view

1. Timer display

- Displays total recording time. When the recorder start recording, this display will start counting up from 0:00 to 9:59.

2. RESET: Timer reset button & standby button
 - Press the RESET button to bring the system into standby mode and reset the timer to 0:00. During standby mode the system will trigger the cassette recorder when the Fire Alarm signal is detected.
3. FIRE ALARM: Fire Alarm detect indicator
 - Lights up when fire alarm is triggered.
4. PUBLIC ADDRESS: Public Address detect indicator
 - Lights up when public address communication occurs.
5. FIREMAN INTERCOM: Fireman Intercom detect indicator
 - Lights up when there is a conversation that use the fireman intercom system.
6. RECORD ON: Recording indicator
 - Lights up whenever the system is recording emergency voices.
7. CASSETTE OUT: Cassette Out indicator
 - Lights up when the cassette tape is remove from the recorder.
8. CASSETTE END: Cassette End indicator
 - Lights up when the recorder stops recording, when the system is not in standby mode or when the tape is ended during the recording process.

2.1.2 Terminal blocks

All of the interfacing connections are located at the Fireman Intercom Master Console panel (refer to Fireman Intercom user manual). The following figure shows the Cassette Interface module connection terminal block.

FIREMAN INTERCOM SYSTEM MASTER CONSOLE PANEL

FROM OTHERS								TO RECORDER							
+24VDC (BR)	0V (BK)	COM (PK)	FIRE ALARM (GY)	COM (PK)	PUBLIC ADDRESS (VD)	COM (PK)	FIREMAN INTERCOM (GR)	AUDIO - (BK)	AUDIO + (YE)	0V (BK)	COUT (RD)	CEND (YE)	PAUSE/ REC (BL)	RTN (WH)	REC (OR)

Figure 2-2 The cassette interface module terminal block

24V DC Power Supply

1. +24 V (Brown)
2. 0V (Black)

Input trigger source

3. COM (Pink)
4. FIRE ALARM (Grey)
5. COM (Pink)
6. PUBLIC ADDRESS (Violet)
7. COM (Pink)
8. FIREMAN INTERCOM (Green)

To Cassette Recorder

9. AUDIO- (Fireman Intercom audio(-) signal to Recorder LINE IN input)
10. AUDIO+ (Fireman Intercom audio(+) signal to Recorder LINE IN input)
11. 0V (Black)
12. COUT (Red)
13. CEND (Yellow)
14. PAUSE?REC (Blue)
15. RTN (White)
16. REC (Orange)

Note:

DO NOT connect the supply 0V and Input trigger COM together

2.2 Modified Cassette Recorder

The following diagram shows the rear view of a typical modified cassette recorder. The modified recorder can operate on 230V AC or 24V DC backup supply.

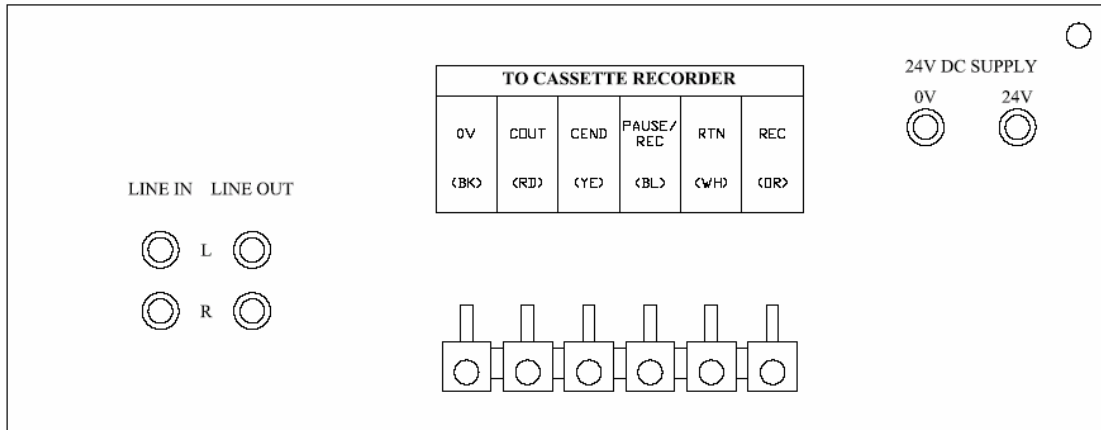

Cassette Recorder

Figure 2.3 Typical Modified Cassette Recorder's Back View

- | | |
|--------------|----------|
| 1. 0V | (Black) |
| 2. COUT | (Red) |
| 3. CEND | (Yellow) |
| 4. PAUSE/REC | (Blue) |
| 5. RTN | (White) |
| 6. REC | (Orange) |

Voice traffic from public address system and fireman intercom system can be plugged into LIFT or RIGHT channels of the modified recorder's LINE IN INPUT respectively

A 24V DC backup supply is needed in the event of AC failure.

Chapter 3 System Operation

This chapter describes about the EVC7790 system operation including

- System setup procedure
- System Operation

3.1 System Setup Procedure

3.1.1 Connection and Power Supply

1. Connect the cassette interface panel according to the diagram provided in Figure 3.1.
2. Switch on the 230V AC main for the modified cassette recorder and the 24V DC supply for the Cassette Recorder Interface Panel.

**Fireman Intercom System
Master Console Panel terminal Blocks**

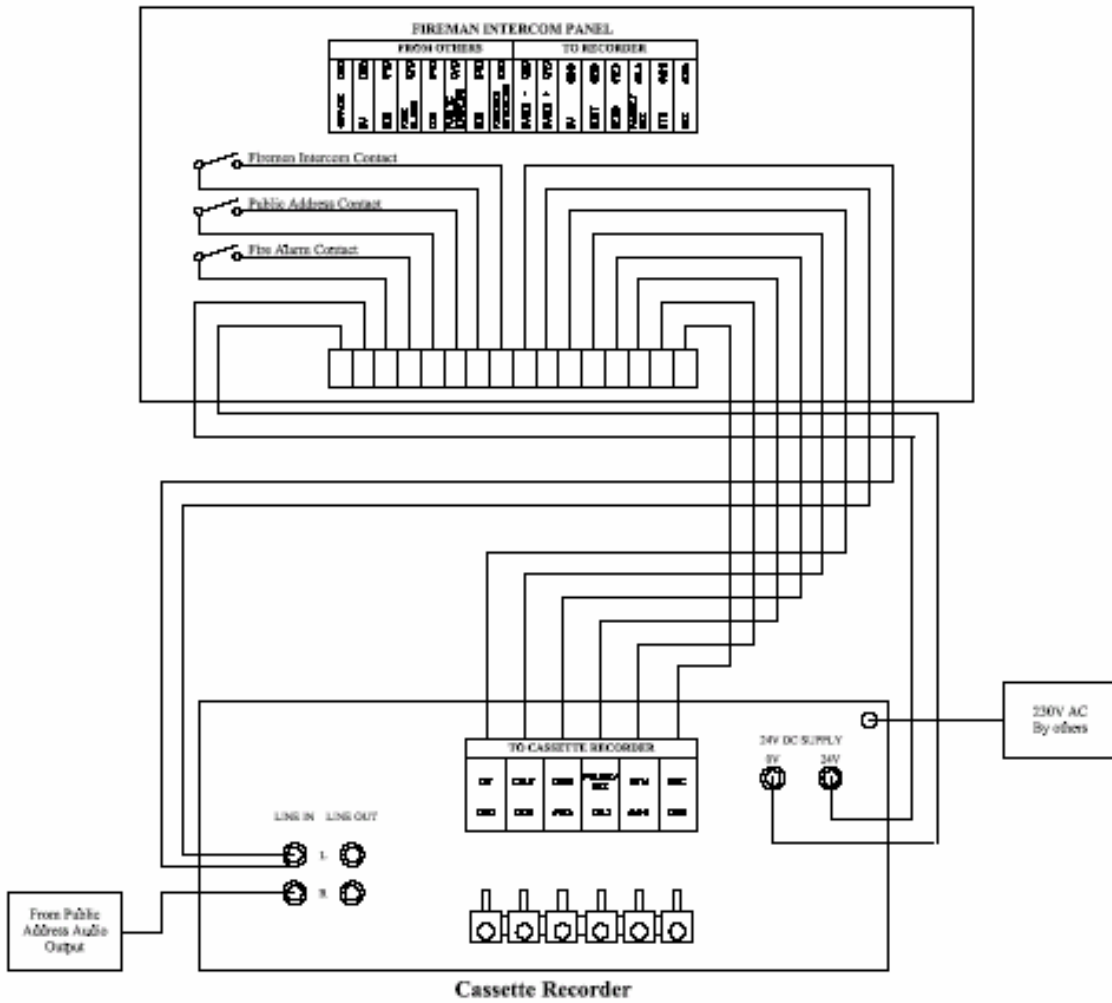

Figure 3-1 EVC7790 (Module) System connection & power supply setup

3.1.2 Modified Cassette Recorder

3. Switch on the Modified Recorder power supply switch located at the front panel.
4. Load in a NEW cassette tape with a 120 minutes recording duration into the right deck. Only the right deck can perform the recording task.
5. Set the DOLBY NR switch according to the tape specification.
6. Set the REVERSE MODE switch to play back of both cassette sides to permit a 120 min. recording mode.
7. Set the REC. LEVEL knob to the satisfactory level by observing the signal level strength display on the front display panel.
8. To obtain satisfactory recording, refer to the user manual provided with the cassette recorder.

3.1.3 Cassette Interface Display Panel

9. Turn on the 24V DC power supply for the cassette interface panel.
10. The timer display and cassette end indicator will light up. After a few seconds, the cassette end light starts blinking while the colon at the timer display starts toggling.
11. Press the reset button on the cassette interface panel.
12. Cassette end indicator at the interface panel will turn off. The PAUSE & RECORD lights at the modified recorder will blink, indicating that the system is now on stand-by mode.
13. The recorder unit is now in the standby mode for recording.
14. System setup procedures complete.

3.2 System Operation

3.2.1 Bringing the System into Standby Mode (Reset Button)

To bring the system into standby mode, press the reset button on the cassette interface panel.

It will reset the timer display, and at the same time, it will make the cassette recorder to be ready for recording.

3.2.2 Recording Process

During the standby mode, the EVC7790 will start recording as soon as the fire alarm input is triggered. Even if the fire alarm occurs while the system is not in standby mode, the system will automatically go into standby mode and start the recording process. Triggering of fire alarm input will make the Fire Alarm indicator on the cassette interface panel to light up.

Once the recording is started, the timer display will start counting up in terms of minutes. It can keep track of the recording duration up to 9 hours and 59 minutes. When the maximum limit is reached, the counter will restart again from 0 hour 0 minute.

In addition, the RECORD ON indicator will light up during the recording process. This recording process can only be stopped by pressing the STOP button at the modified recorder.

After the recorder stops recording, the system will display the total recording time at the timer display. By pressing the reset button again, the system goes into standby mode whereby the recorded time is cleared back to zero.

3.2.3 Cassette Out & Cassette End

These two signals are indicated on the cassette interface panel by the two amber indicators. Whenever the cassette tape is not inside the modified recorder, the cassette out indicator will blink.

Similarly, cassette end indicator will blink whenever the system stops recording, or the recording tape reaches its end.

Chapter 4 Frequently Asked Questions

Is the 'Ground' same as the '24V supply ground'?

- | |
|--|
| <ul style="list-style-type: none">• Yes. |
|--|

Public address / Fireman Intercom indicator light up, but no recording

- | |
|---|
| <ul style="list-style-type: none">• EVC 7790 will start recording only when the Fire Alarm input is triggered• Fire Alarm LED will light up when the Fire Alarm input is triggered |
|---|

Fire Alarm indicator lights up, but no recording

- | |
|---|
| <ul style="list-style-type: none">• Check the connection of Fire Alarm input at the back of the cassette interface panel• Check the Cassette Out, and Cassette End indicators. If the cassette tape is out or the cassette tape reaches the end, recording could not start. In this case, insert a new tape. |
|---|

Can I change a new tape during recording?
--

- | |
|---|
| <ul style="list-style-type: none">• Yes. After changing a new tape, EVC7790 will check for the Fire Alarm input. If the Fire Alarm input still triggers, the system will start recording again. |
|---|

What actually is the Reset button for?

- | |
|--|
| <ul style="list-style-type: none">• Reset button is to reset the total recording time lapse displaying on the timer display, and bring the system into Standby mode.• Pressing reset button during recording process is not advisable since it will clear the total recording time to zero. |
|--|

My system only records for 1 hour only, then it stopped.

- | |
|---|
| <ul style="list-style-type: none">• Check the modified recorder. Is the Reverse Mode enabled? If it is not enabled, the recorder will record only one side of the tape, e.g. side A.• Check the cassette tape capacity, 60 or 120. |
|---|

Notes

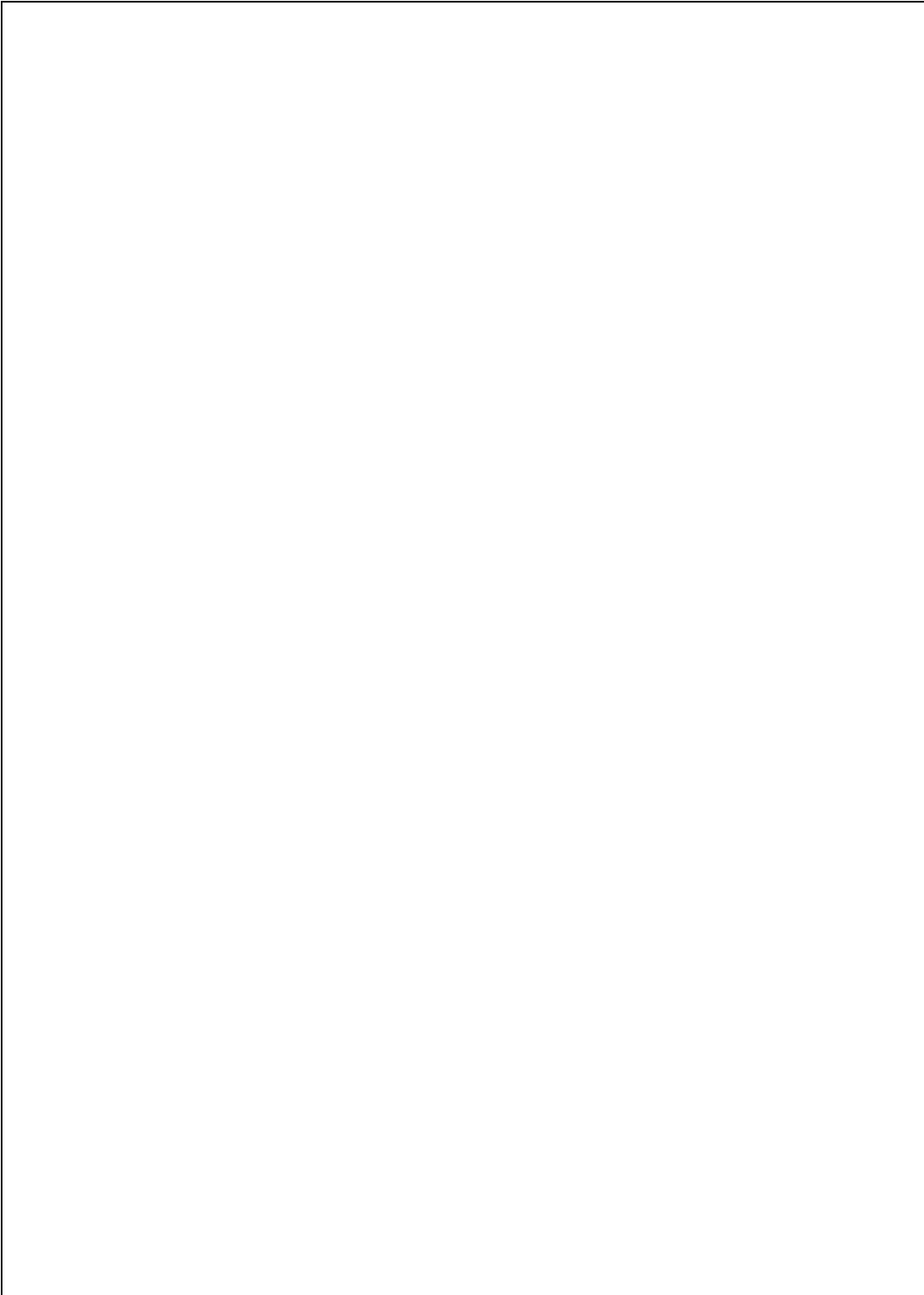

Cassette Recorder User Manual